

SCHIEDEL

ePURO

Electrostatic Particle Filter for Residential Appliances

Installation, Operation, Maintenance
and Servicing Manual

www.schiedel.com/uk

February 2023

Table of Contents

Inhalt			
General Information	3	Switching on externally	16
Advantages of an electrostatic precipitator	3	Connection ePURO filter with display	17
Inform your chimney sweep	3	Electrical connection OekoTube and fan	18
Notes on maintenance	3	Maintenance and Cleaning of the ePURO filter	19
Operating principle	4	Safety	19
Switch-on	4	Cleaning brush	19
Significance of the LED-Signal	5	Cleaning from below	19
Description of the ePURO filter	6	Cleaning from above	20
Scope of delivery	6	Cleaning cycle of the box, the insulator and the connecting pipe (every 2-4 years)	20
Overall view	6	Fault Indication / Fault Reason	21
Detailed view	6	List of cause of error	21
Installation Instructions	7	Hexagonal bar is not trimmed to length	21
Fireplace structure	7	Missing magnet, or it is too far away from the contact	22
Toolkit	7	Soot build up in the extension tube and / or the insulator	22
Installation	7	The electrode is not centered	22
LED-Signal: Test Mode and Normal Mode	11	The electrode is too long	22
Electrical Connection	12	Dip-Switches Setting	22
General information	12	Setting Dip-Switches	22
Connection of the appliance plugs	12	Factory setting	23
Electrical specifications ePURO filter	12	DipSwitch	23
Electrical connection ePURO filter	13	Switch-on behaviour	24
Electrical connection ePURO filter with LED indoor (special circuit board, optional, only indoor)	13	Addressing the HV modules	24
Electrical specifications LED (special circuit board, optional, only indoor)	14	Display as Master	25
ePURO filter Inside Control: Schematic and Terminal Block	14	Type Plate	25
Detailed view Terminal designation	14	EC Declaration of Conformity	26
Connection LED External	16	Fact Sheet ePURO filter	27

General Information

Safety notes



Please read these instructions carefully before installing the ePURO filter.

- Before carrying out any work on the ePURO filter, the power supply must be disconnected (mains plug or fuse).
- The installation may only be performed by authorized and competent personnel.
- The distance to combustible building materials is at least 400 mm for the ePURO filter without insulation.
- The local and country-specific guidelines and regulations must be observed for all work on the flue system.
- Before installation, the statics of the flue system must be checked and appropriate measures implemented if necessary.
- Before installation, check the flue system for fire safety and any deposits.
- The ePURO filter must be accessible for maintenance.
- Before any maintenance work, the combustion system must be shut down and the flue pipe must be cold.
- Cleaning and disposal of deposits (ash and dust) must be carried out with great care and suitable protective equipment due to exposure to organic substances that may be harmful to health.
- Warning notices must be attached to the chimney.
- The owner must inform the chimney sweep about the installation of an ePURO filter.

No liability is accepted for accidents or damage caused by failure to observe these instructions.

Advantages of an electrostatic precipitator

Electrostatic precipitators offer several advantages over other dust removal filters like wet scrubbers and traditional filters:

- High efficiency also in filtering out the smallest particles.
- Little back end loss or drop in pressure.
- Low Maintenance and operating costs.
- No expendable parts.

Inform your chimney sweep

The owner has to inform the chimney sweep about the installation of an ePURO filter

Notes on maintenance

Depending on the capacity and the frequency of using the wood heating, maintenance may need to be carried out on the filter from every 2 - 5 years. The ePURO filter should therefore be easily accessible.

Operating principle

The ePURO filter functions on the electrostatic principle. The micro-dust particles are flowing through the flue. A high voltage electrode emits electrons. Due to the electrostatic force, the electrons move towards the chimney wall. During this process, the microdust becomes electrostatically polarised and therefore moves towards the chimney wall.

The micro-dust particles are collected on the inside wall of the chimney and clog together into coarse flakes. This particulate matter is then removed by the chimney sweep during the annual chimney inspection.



1. Fine dust particles flow through the exhaust duct with the exhaust air.

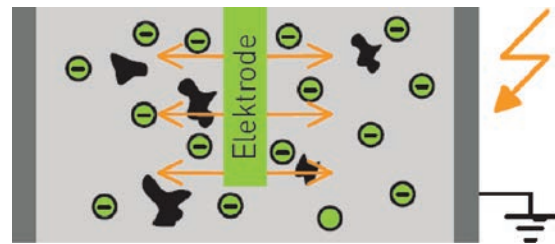

2. Electrons are released by a high voltage electrode.

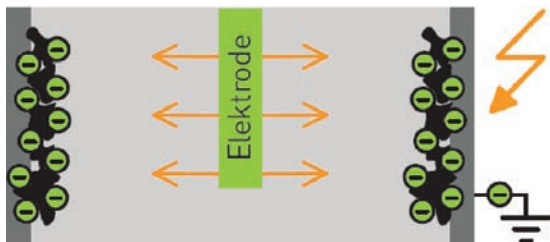

3. The fine dust particles are electrostatically charged and moved towards the chimney wall.

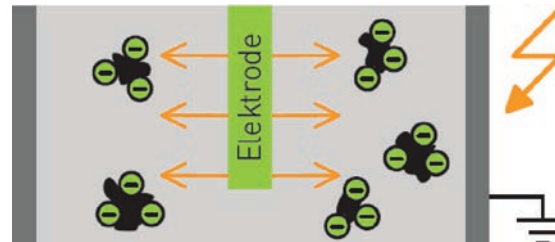

4. The fine dust accumulates on the chimney wall and clumps together to form coarse particles.

Switch-on

The ePURO filter switches on automatically when the exhaust gas temperature rises. It switches off when the temperature falls below a certain threshold.

Significance of the LED-Signal

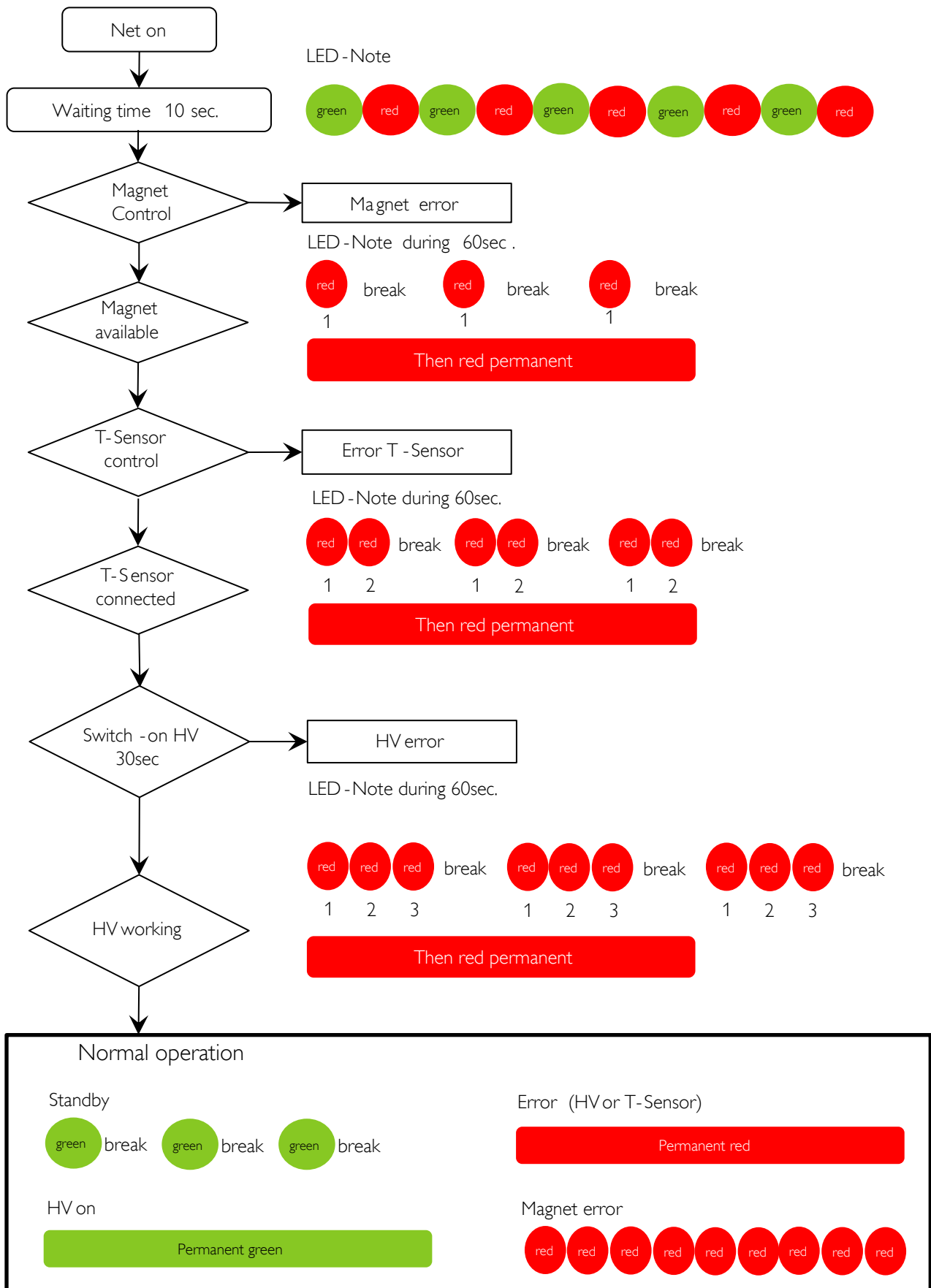

Description of the ePURO fil-

Scope of delivery

- | | |
|---|---------------------------------------|
| 1. Electronic box with springs, nuts and insulator | 6. Cover |
| 2. Console | 7. Mounting bracket for brick chimney |
| 3. Flexible electrode with 6-edged electrode holder | Optional |
| 4. Temperature sensor (cable and holder) | 8. T-piece |
| 5. Main plug (110 V / 230 V AC) | 9. Extension pipe 500 mm |

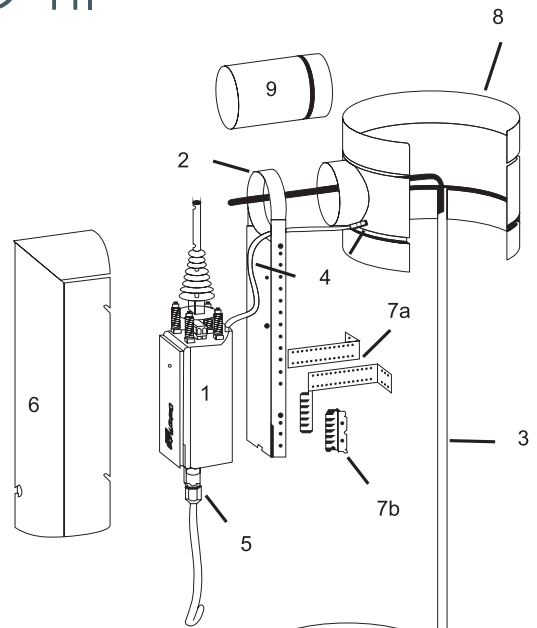

Overall view

Brick-lined chimney Single Wall Tee

- | | |
|---|----------------------------|
| 1. T-piece | 8. Assembly bracket |
| 2. T-piece connector (panel connection) | 9. Electronic box |
| 3. Extension pipe (ME Pipe) | 10. Electrode |
| 4. 6-edged electrode holder (steel rod) | 11. The mains plug 230V AC |
| 5. Insulator | 12. Cover |
| 6. Panel | 13. Terminal |
| 7. Temperature sensor with holder | |

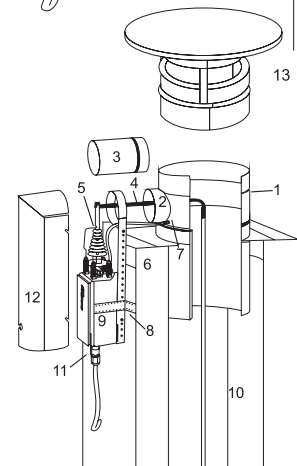

Detailed view

- | |
|---|
| 1. Electronic box |
| 2. Springs |
| 3. Adjusting nuts |
| 4. Insulator |
| 5. Grub screw to fix the hexagonal electrode holder (6) |
| 6. Hexagonal electrode holder (steel rod) |
| 7. Electronic box mounting bracket |
| 8. Extension pipe |
| 9. T-piece connecting piece |
| 10. Temperature sensor and cable holder |
| 11. Flexible electrode |
| 12. T-piece |
| 13. Mounting bracket |

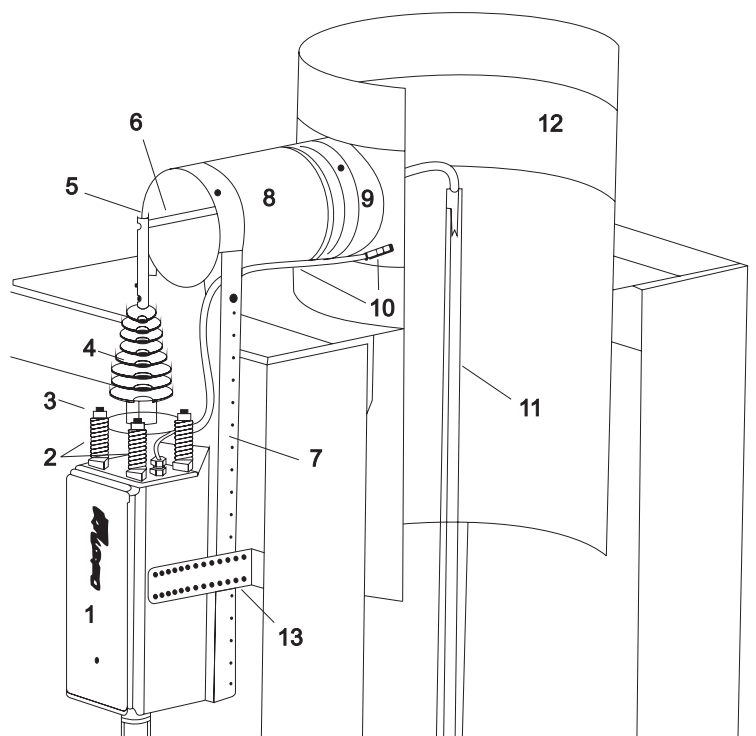

Installation Instructions

Fireplace structure

Depending on the type of the chimney the ePURO filter has to be installed with professional expertise.

Please follow these installation instructions for a traditional brick or masonry chimney:

Masonry stack

- Anchor Plate
- SW or DW Tee piece connector
- Terminal

Toolkit

- Cordless screwdriver / hammer drill for brick chimneys
- 3mm Allen key (all screws can be tightened with the same Allen key)
- Metal drill 3,3 mm
- Concrete drill (brick chimney)
- Open-end spanner size 17
- Screws and anchors (brick chimney)
- Hand torch
- Spirit level

Installation - Brick lined chimney

Step 1: Fitting the T-piece

1. Remove chimney pot or other terminal.
2. Fix the anchor plate to the top of the chimney using suitable masonry bolts through the pre-drilled holes in each corner. The plate should be bedded into a layer of fire cement.
3. Attach the tee piece to the anchor plate and fix in position with the locking band.
4. Attach the electrode ensuring it protrudes through the branch of the tee.
5. Attach the extension pipe to the branch of the tee using a locking band.
6. Slide the loop of the support console (Part 2) over the extension pipe.
7. Fix the support console to the masonry stack using the fixing brackets (Part 4b)

Step 2: Installation of the electrode and the electronic box

1. The flexible electrode is inserted through the T-piece into the flue pipe.
2. Unscrew the grub screw on top of steel rod above the insulator. Push the hexagonal steelrod from the electrode through the hole. Do not cut the hexagonal rod yet.
3. Push the electronic box with the two holes on top forward over the two screws in the console. Slide the electronic box along the console downwards over the bottom hook, so the electronic box sits secure and cannot slip. Tighten the two screws with a 3 mm Allen key.

ATTENTION!

Do not use cordless screwdriver.
Danger of corrosion of the stainless screws.

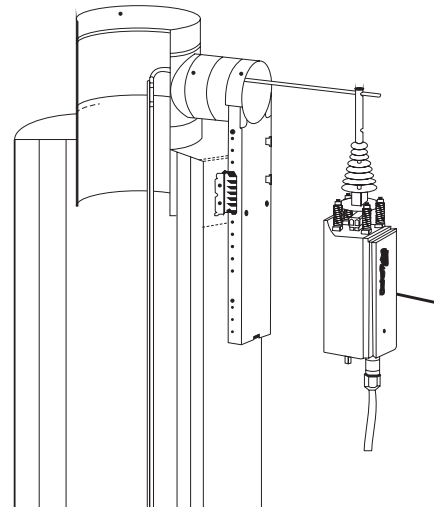

Step 3: Alignment of the electrode

ATTENTION!

Make sure that the flexible electrode is positioned absolutely centered of its entire length in the flue pipe. Thereby a trouble-free functioning of the OekoTube can be ensured.

1. Check if the „upper end“ of the electrode is positioned centrally in the chimney flue. Keep the insulator rod vertically to prevent the hexagon leverage effect. Tighten the grub screw temporarily. **NOTE:** Use the grinder's cut-off disc or a hacksaw to cut off the rest of the hexagon rod a few centimeters behind the grub screw. Then the leverage effect is eliminated by the weight of the hexagon.
2. Check if the „upper end“ of the electrode is still positioned absolutely centered in the flue pipe. If necessary, adjust the position of the hexagon rod using the grub screw.
3. Check if the grub screw is tight.
4. Fine adjustment: Align the electrode exactly in the middle of the flue pipe along its entire length using the eight nuts above the springs.

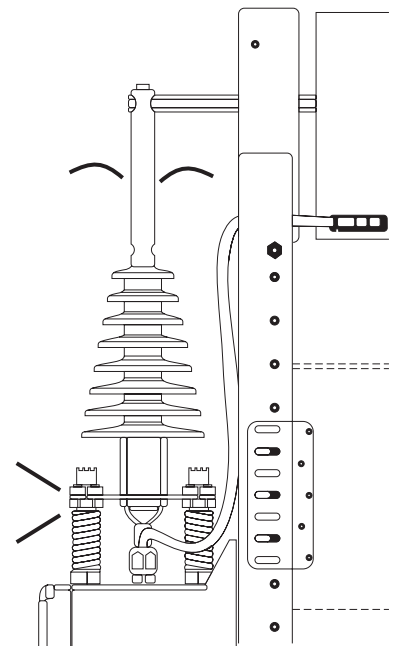

Minimum distance between the electrode and chimney wall: 50 mm

NOTE: The insulator rod may be slanted.

5. When the electrode on the whole length is vertical, tighten all nuts with the open-end spanner (size 17).
6. With a circular or metal saw, crop the 6-edged rod.

Step 4: Mounting the temperature sensor for ePURO filter

1. Insert the temperature sensor into the holder, the tip of the sensor should protrude through the hole in the tee branch by c. 3mm. Tighten the screw on the holder once in position to prevent the sensor from slipping back out. (fig. 1).
2. Secure the cable of the temperature sensor into the two notches on the console. Make sure the cable is not over-stretched (fig. 2).
3. Roll up the remaining cable of the temperature sensor and secure it onto the springs (fig. 2). Make sure that the cable does not contact the insulator.

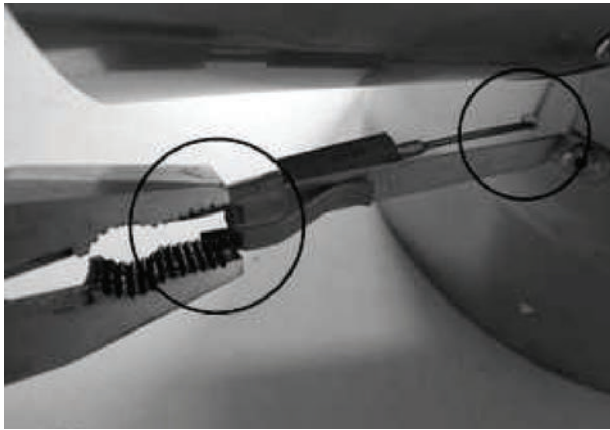

Figure 1

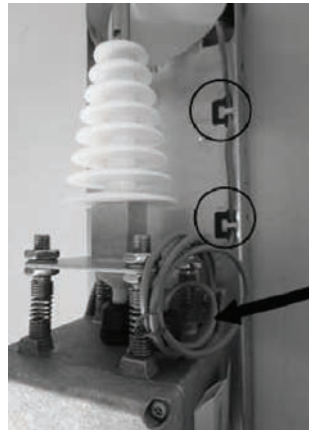
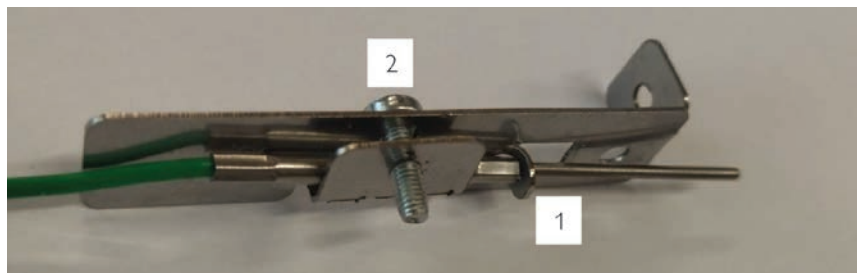

Figure 2

Temperature sensor without spring

1. Guide the temperature sensor through the guide eyelet [1].
2. Tighten the screw [2].



Step 5 – Prior to mounting the cover, make sure that:

1. Hexagonal rod is cut off flush and the sharp edges grounded or sanded back to a smooth surface
2. The 2 screws on the electronic box are tightened
3. The nuts above the springs are tightened
4. The temperature sensor is riveted and fixed at the right place and sticks out into the flue pipe
5. The cable of the temperature sensor is installed
6. The grub screw used to secure the hexagonal holder (steel rod) is tightened
7. Inspection view: The electrode is positioned
8. The plug is connected

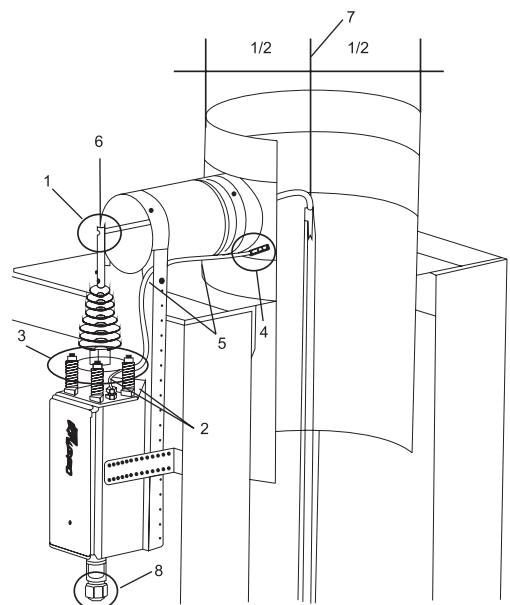

Step 6: Fitting the cover

1. Fasten the cover with the 4 available screws.
2. Do not use cordless screwdriver; Danger of corrosion of the stainless screws

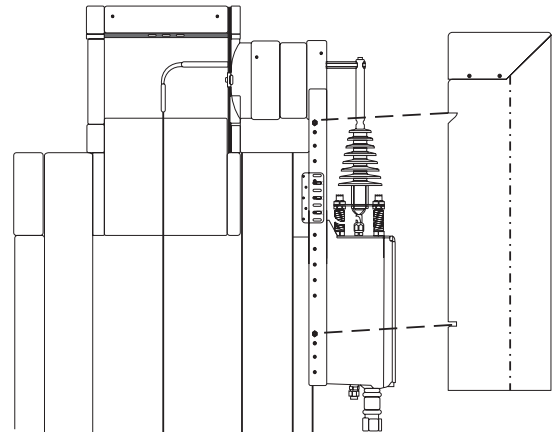

Step 7: Affix the appropriate warning signs

The chimney sweep has to be aware of that the chimney is equipped with an ePURO filter. Affix a "Warning Sign" on all access doors. Exhaust system with the ePURO filter micro-dust precipitator.

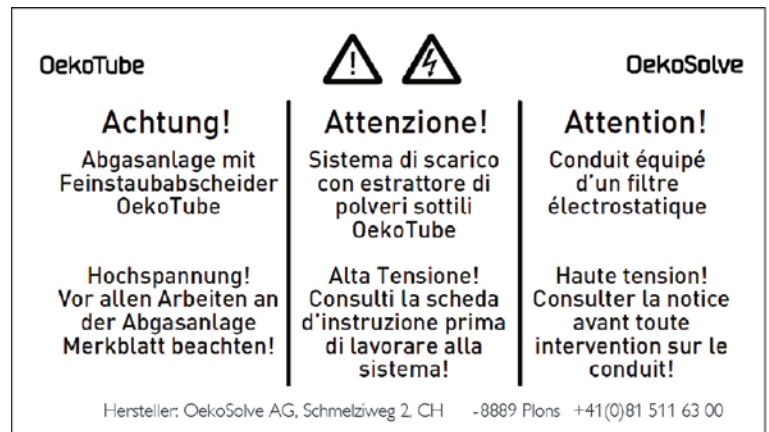

Step 8: Connect the power socket

Connect the plug to the electronic box. The LED blinks orange and then flashes green every 10 seconds if the ePURO filter is on stand-by mode. When the ePURO filter is in operation, the LED light is continuously green. Electrical installations must be performed by a qualified electrician.

LED-Signal: Test Mode and Normal Mode

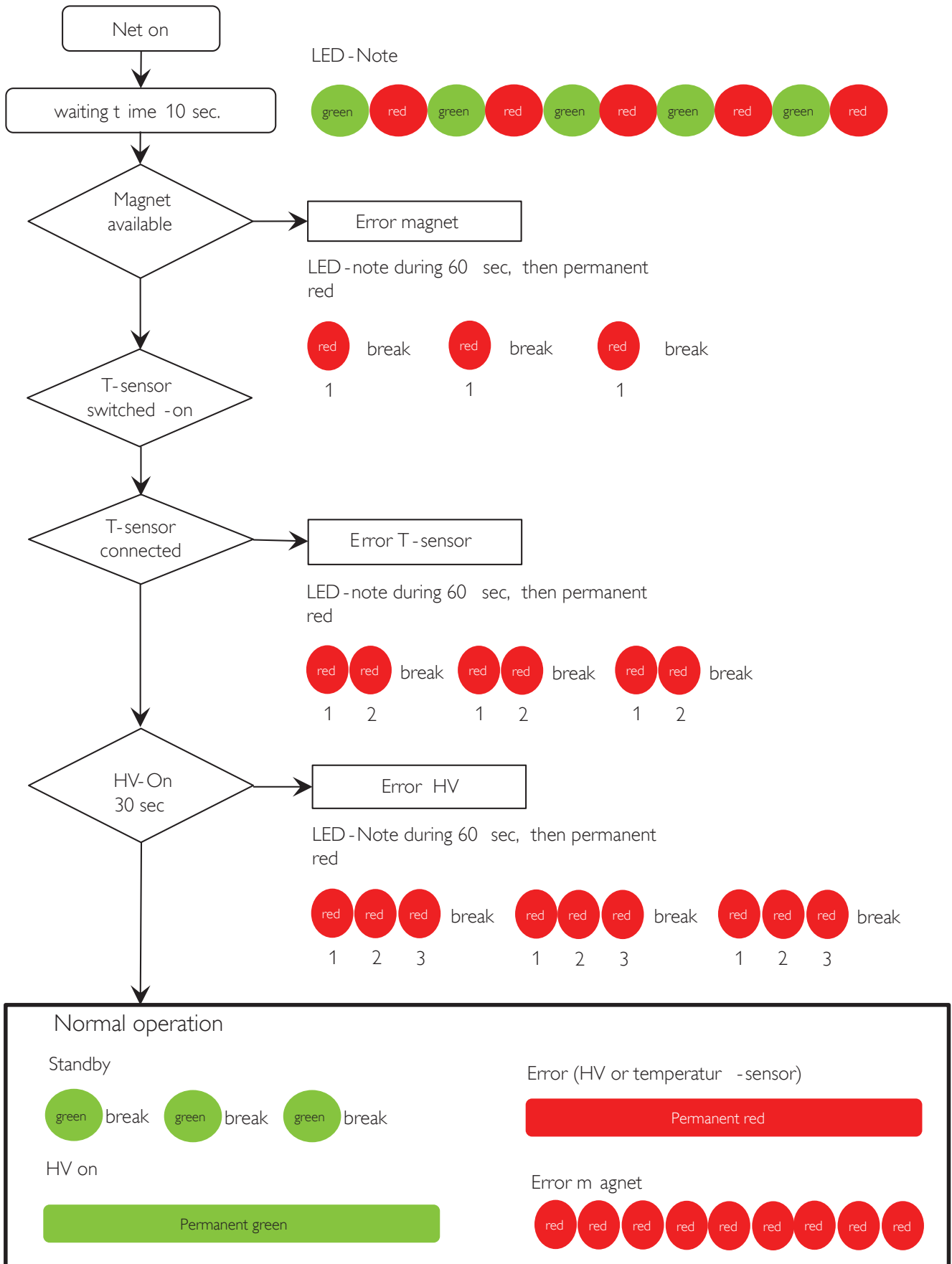

Electrical Connection

General information

The electrical installation must be performed by a qualified electrician. Pull out the plug from the ePURO filter so it is disconnected from the mains. Connector: 110V AC / 230 V AC / 0.2 A / 30W, 50 Hz

Connection of the appliance plugs

Check designation on the connector (L = conductor, N = neutral, earth conductor).

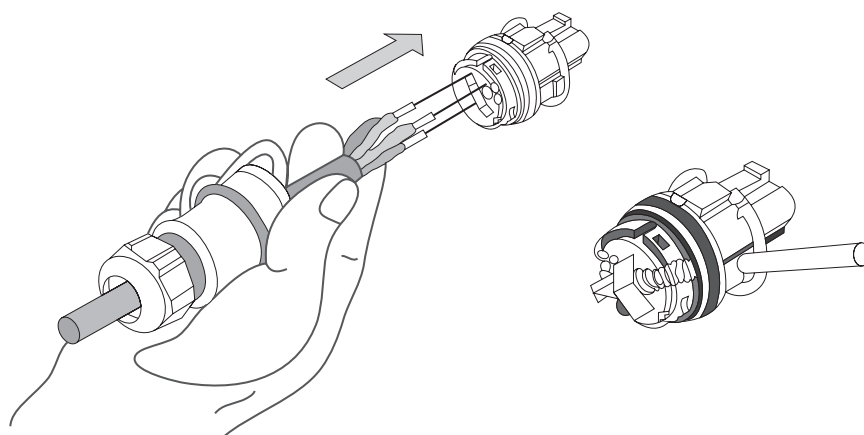

Screw connector:
Tightening torque
Typ. 0.8 – 1.Nm



Electrical specifications ePURO filter

Nominal voltage	110V AC / 230V AC
Rated power	30W
Current consumption	max. 0.2A
Protection class	1
Color code	
Brown:	L1
Blue	N
Green/yellow	PE

Electrical connection ePURO

Cleaning from below

The insulation switch must be accessible to the chimney sweep.

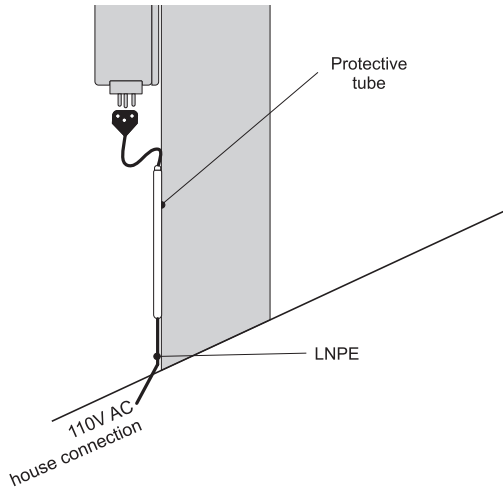

Cleaning from above

The insulation switch must be accessible to the chimney sweep.

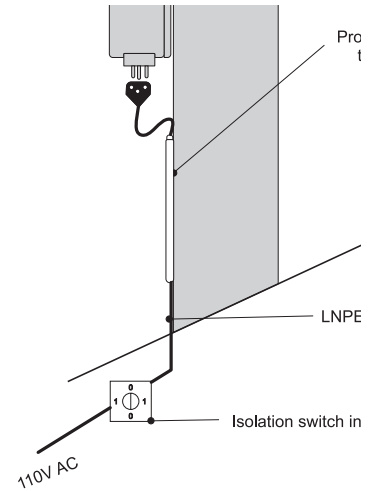

AFFIX THE "CAUTION! PARTICLE PRECIPITATOR!" ON THE INSPECTION DOOR. THE CHIMNEY SWEEP CAN UNPLUG THE EPURO FILTER WHEN CLEANING THE ROOF.

Electrical connection ePURO filter with LED indoor (special circuit board, optional, only indoor)

Cleaning from below

The insulation switch must be accessible to the chimney sweep.

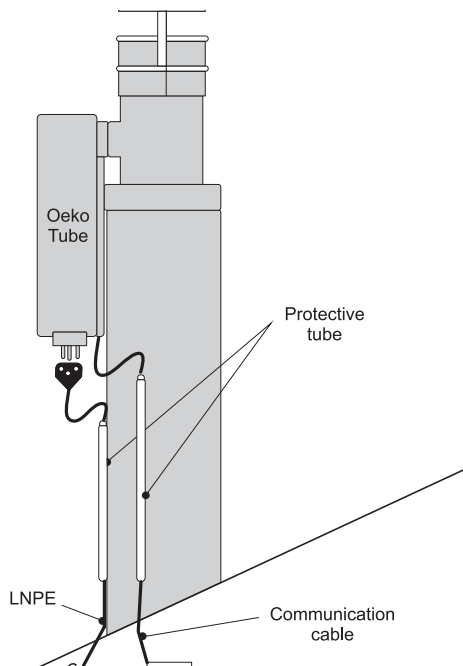

Cleaning from above

The insulation switch must be accessible to the chimney sweep.

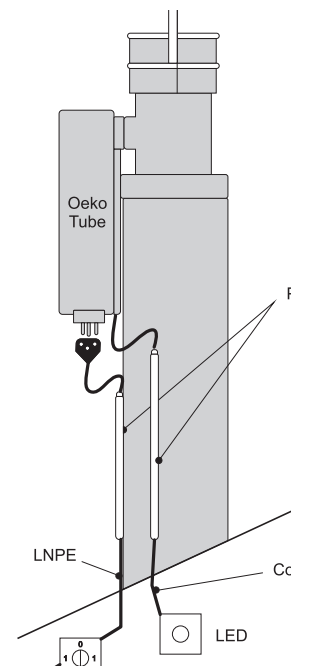

AFFIX THE "CAUTION! PARTICLE PRECIPITATOR!" ON THE INSPECTION DOOR. THE CHIMNEY SWEEP CAN UNPLUG THE EPURO FILTER WHEN CLEANING THE ROOF.

Electrical specifications LED (special circuit board, optional, only indoor)

Max. voltage	24 V
Max. current	10 mA

ePURO filter Inside Control: Schematic and Terminal Block

1. High voltage module
2. Dip switch settings
3. LED, operation indicator
4. Terminal block
5. Power supply unit
6. Dip switch

Detailed view Terminal designation

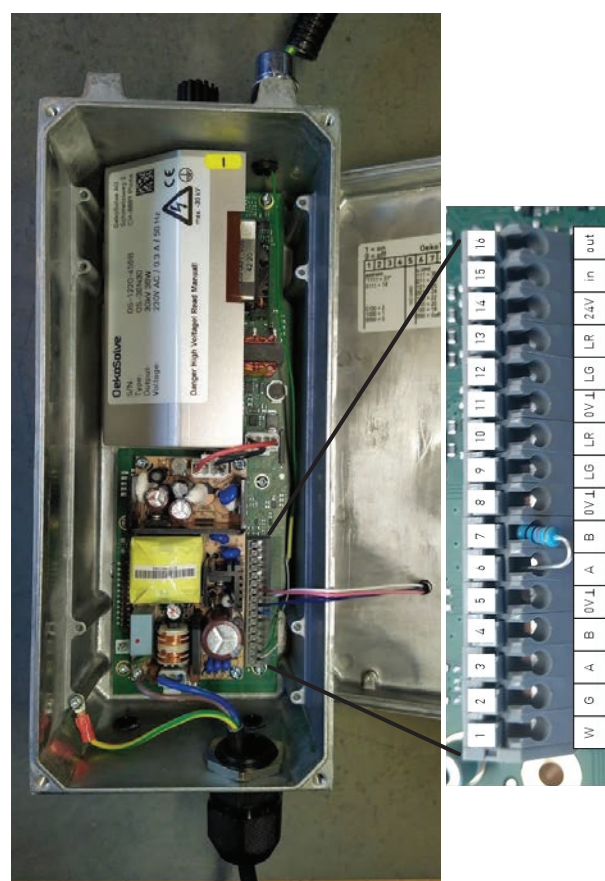

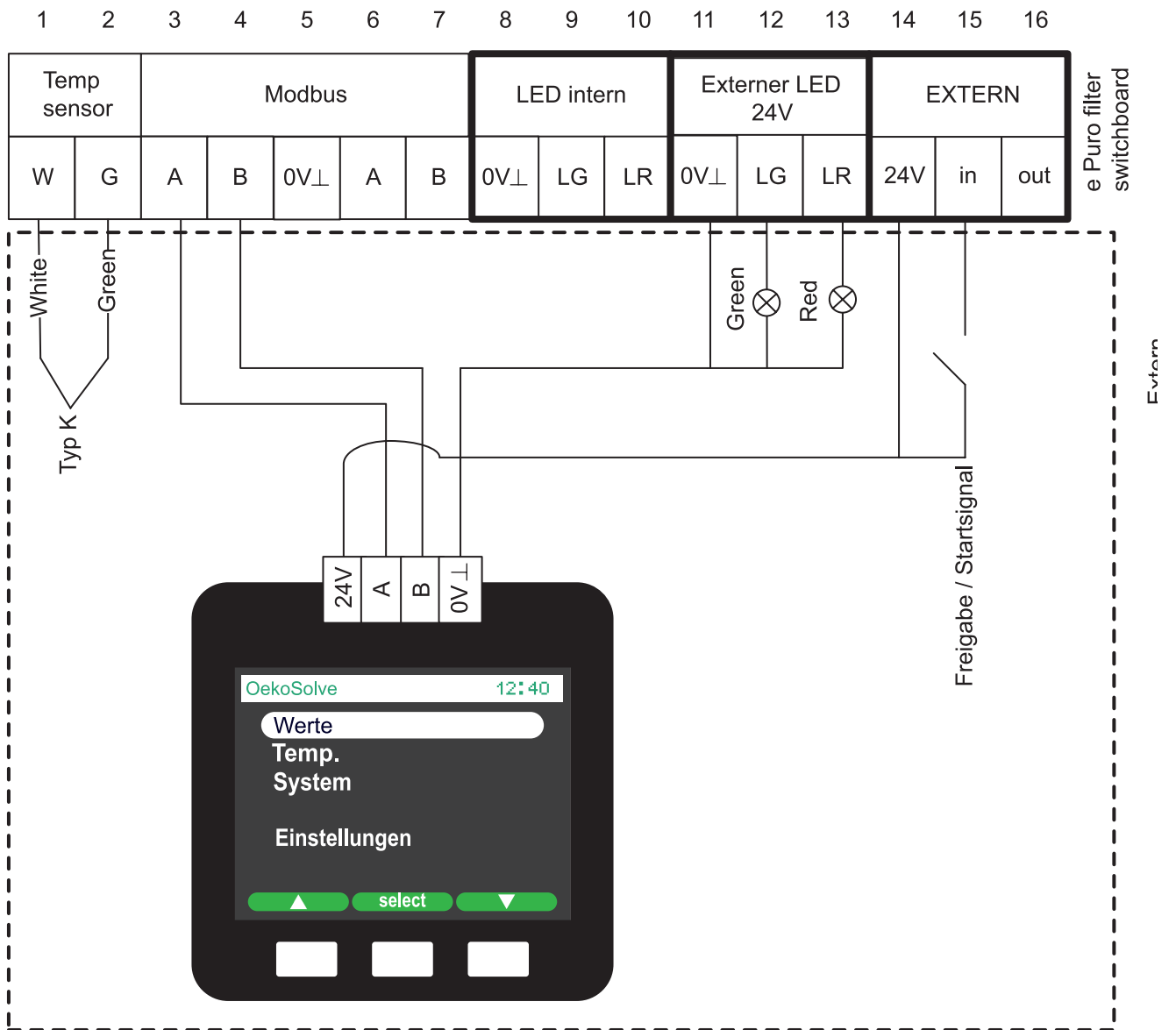

Temperature sensor

- 1 – W – white wire Temperature sensor Type K
- 2 – G – green wire Temperature sensor Type K

Display / Modbus interface

- 3 – A: ModBus +
- 4 – B: ModBus –
- 5 - 0V: Earthing or Modbus
- 6 – A: Reserve ModBus +
- 7 – B: Reserve ModBus –

LED internal in the housing cover

- 8 – 0V: Earthing LED intern
- 9 – LG: Connection green LED internal
- 10 – LR: Connection red LED internal

LED external 24 VDC, max

- 11 - 0V : Earthing LED intern
- 12 – LG: Connection green LED external
- 13 – LR: Connection red LED external

External switch-on and error signal

- 14 - 24V: 24 VDC Output
- 15 – in: Input for external switch-on

Connection LED External

An external LED or light with 24VDC, max. 350mA can be operated via terminals 11-13. The external LED signals the operating status of the separator via a green or red light signal.

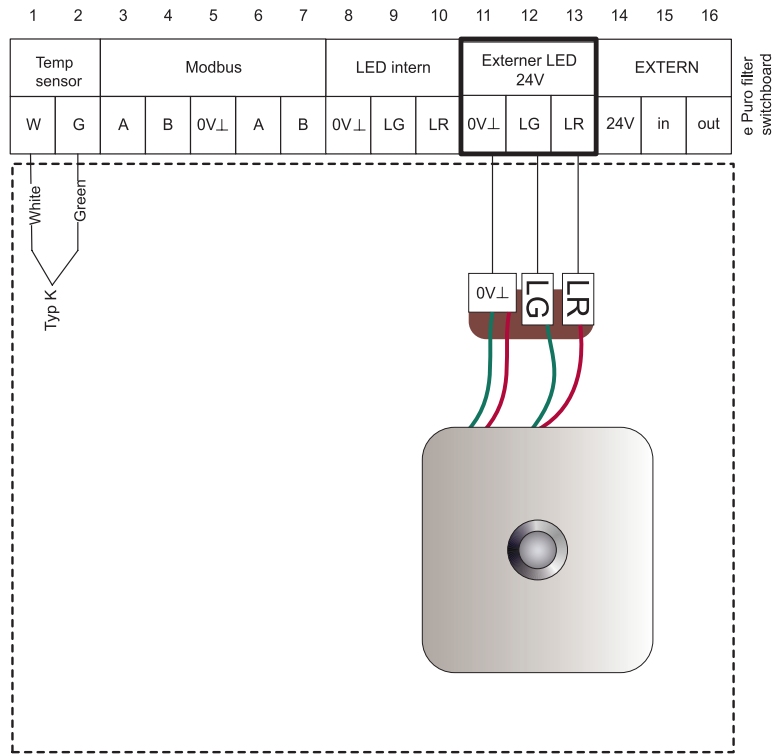

Switching on externally

The OekoTube can be switched on or off via an external switch using terminals 14 + 15. The inputs must or may be wired with max. 24VDC.

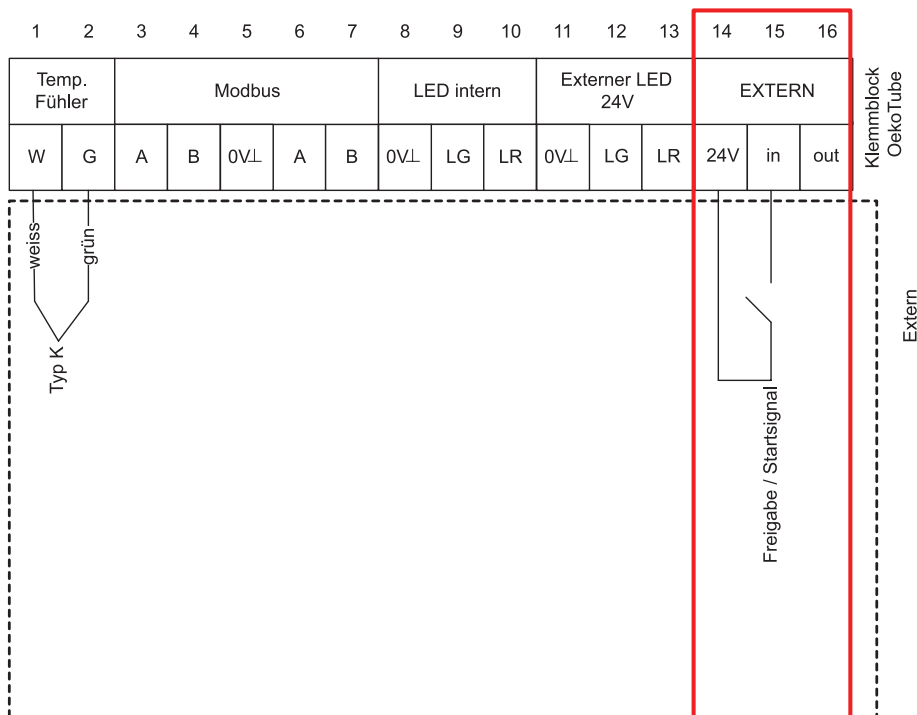

Connection ePURO filter with display

An external display is available as an option, which can be used to read and set operating parameters. The display is supplied with 24 VDC via terminals 11 + 14. Data communication takes place via the Modbus interface on terminals 3 + 4.

Important: To activate the display, the settings on the dip switch must be made as described in chapter 0.

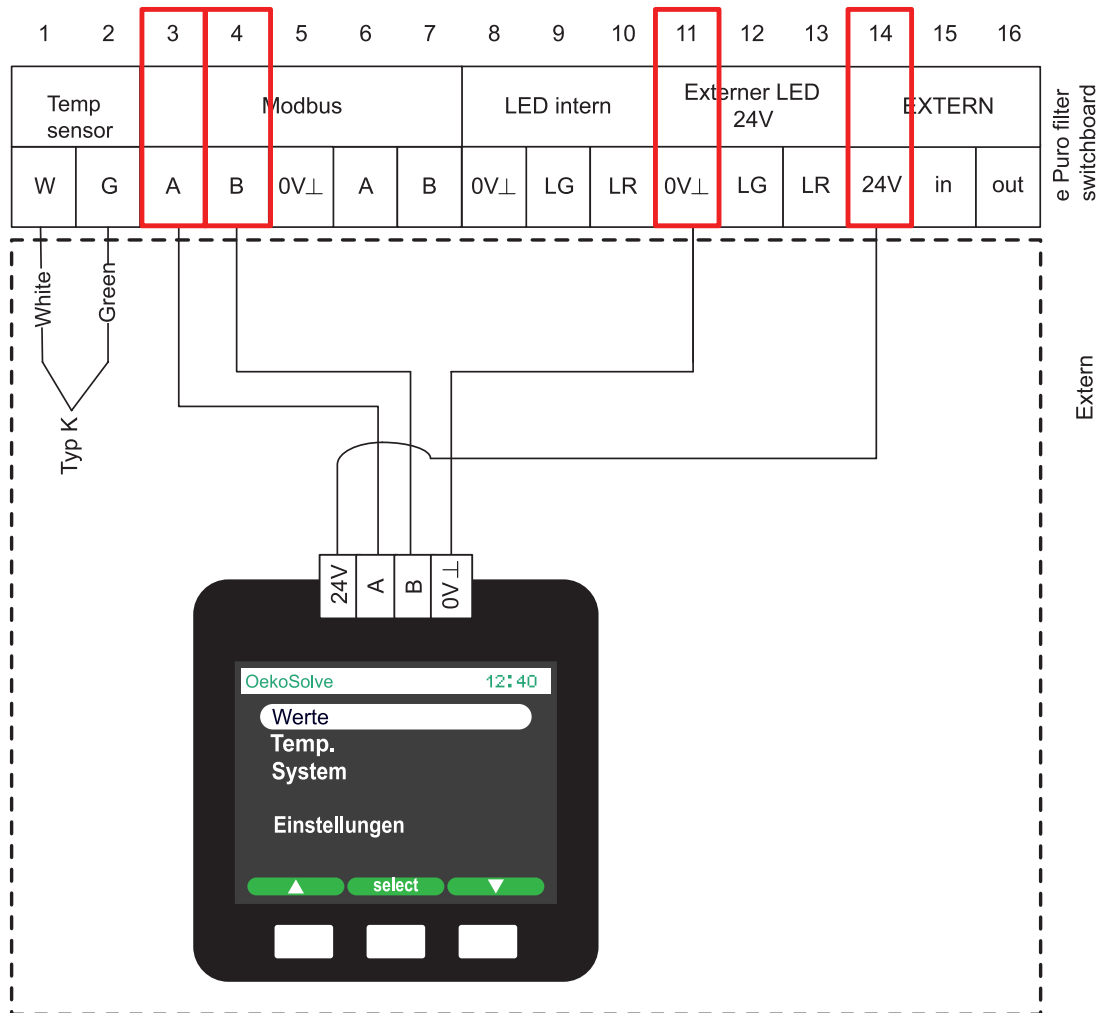

Electrical connection OekoTube and fan

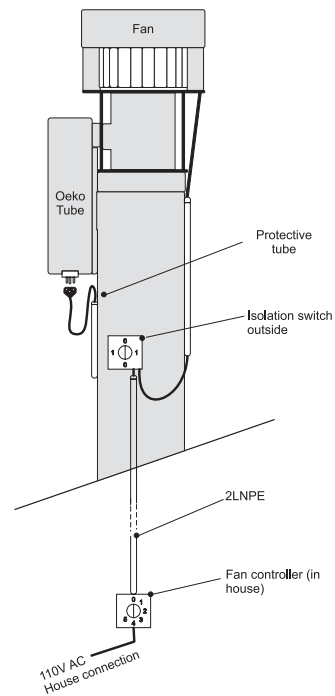
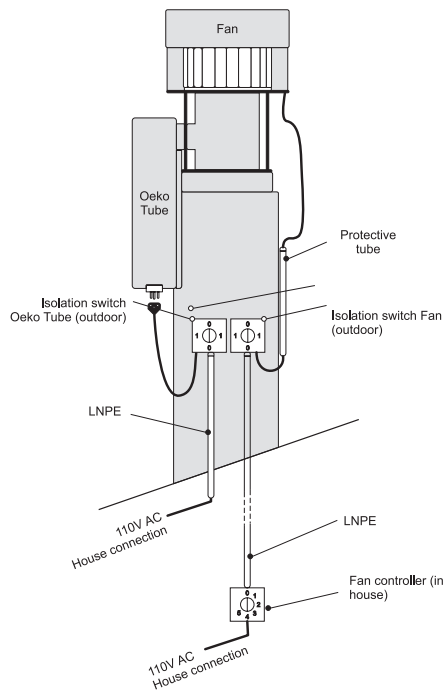

Isolation switch 2 phases supply

2 separate isolation switches

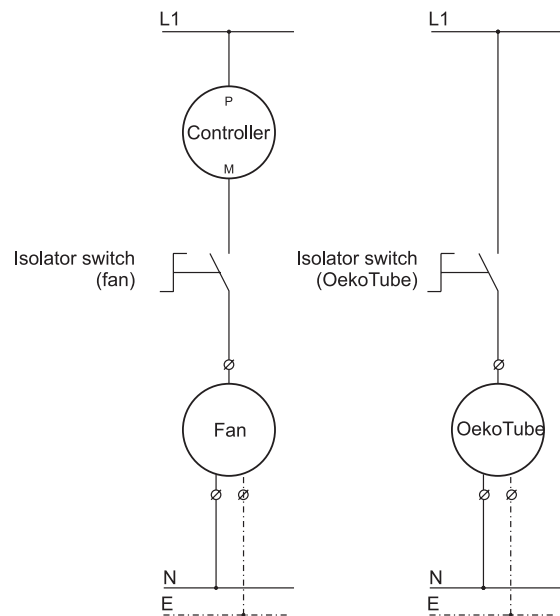
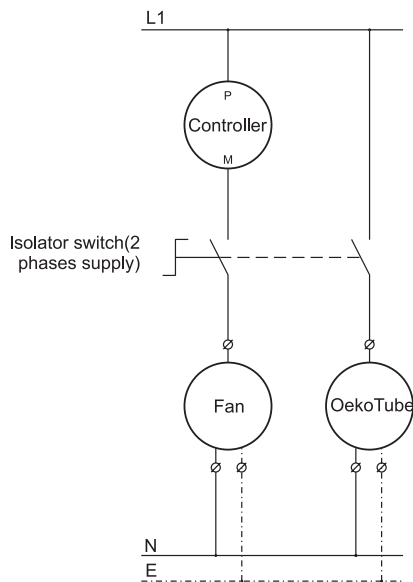

Circuit diagram

Circuit diagram

Maintenance and Cleaning of the ePURO filter

(The interval between cleaning will be determined by the chimney sweep)

Safety

- Before you do any kind of work on the ePURO filter, switch it off (main plug, possibly by switch in the house).
- The cleaning has to be performed only by a skilled and certified expert.
- Through a temperature increase in the exhaust installation the high voltage switches on automatically. During operation, the touching of the electrode or the electrode holder is dangerous to life!
- The precipitator consists of acid-proof and rust-free steel. Do not use a metal brush for the cleaning.
- All works on the roof require one to follow the appropriate guidelines and provisions.

The manufacture of distributors shall not take liabilities for accidents or damages caused by inobservance of these instructions.

Cleaning brush

We recommend the use of a twisted nylon brush. As the 6-edged holder stands vertical in the chimney pipe, it is useful (in particular for the cleaning from below) to use a brush with a little ball on the top.

ATTENTION!

For the standard cleaning do not remove or open any piece of the ePURO filter!

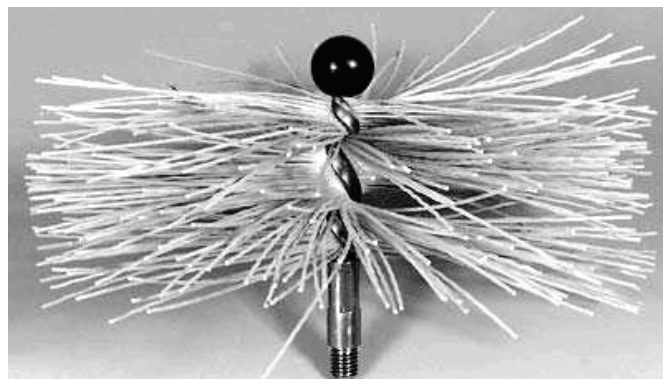

Cleaning from below

1. Switch-off the ePURO filter (main plug, possibly by switch in the house).
2. Carry out sweeping with a synthetic brush. Twisted nylon brushes with a little ball on the top are ideal. This ensures that the brush passes the electrode without any problem.
3. For cleaning right on top of the hexagon, the brush has to be repeatedly pushed up again.

Depending on the degree of soot build up, the extension pipe and the insulator should be cleaned every 2 - 4 years. (Point „Cleaning cycle“)

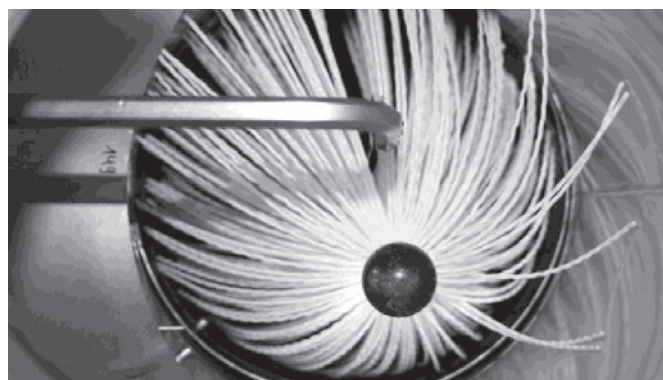

Cleaning from above

1. Switch-off the ePURO Filter (remove the connector).
2. DO NOT remove the electrode.
3. Operate the cleaning with a synthetic brush. Twisted nylon brushes with a little bowl on the top are ideal. This one ensure, that the brush passes the electrode without any problem.
4. The hexagonal bar can be moved to one side by hand and the chimney cleaning can be carried out in the usual.

Depending on the degree of soot build up the extension pipe and the insulator should be cleaned every 2 - 4 years. (Point „circular cleaning“)

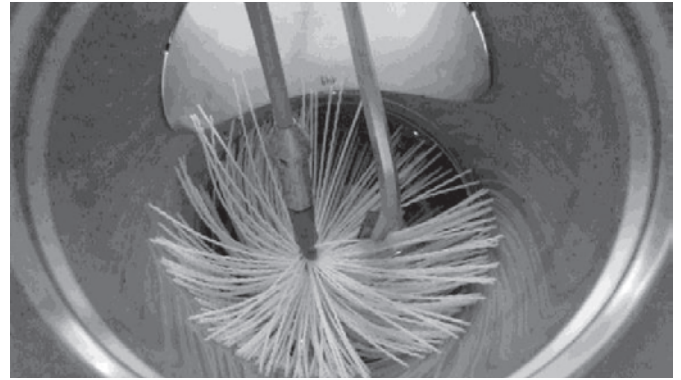

Cleaning cycle of the box, the insulator and the connecting pipe (every 2-4 years)

1. Switch-off the ePURO Filter (remove the connector).
2. Remove the cover (3 Alan screws).
3. Cleaning of the horizontal pipe (130mm diameter)
4. Cleaning of the insulator, the tongues and the electronic box.
5. Re-fix the cover (see point 2)
6. Re-connect the device. Make sure that the LED changes blinking (interval every 10 sec.).

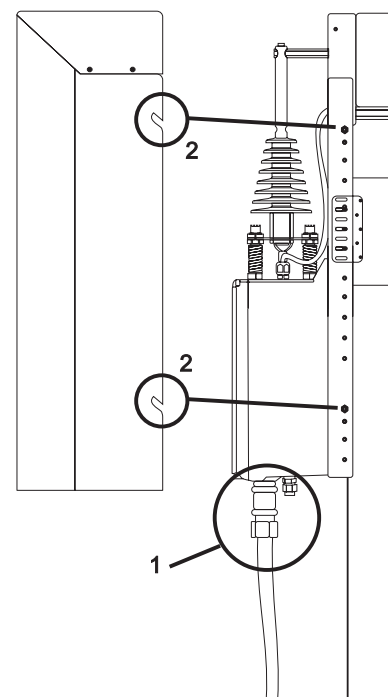
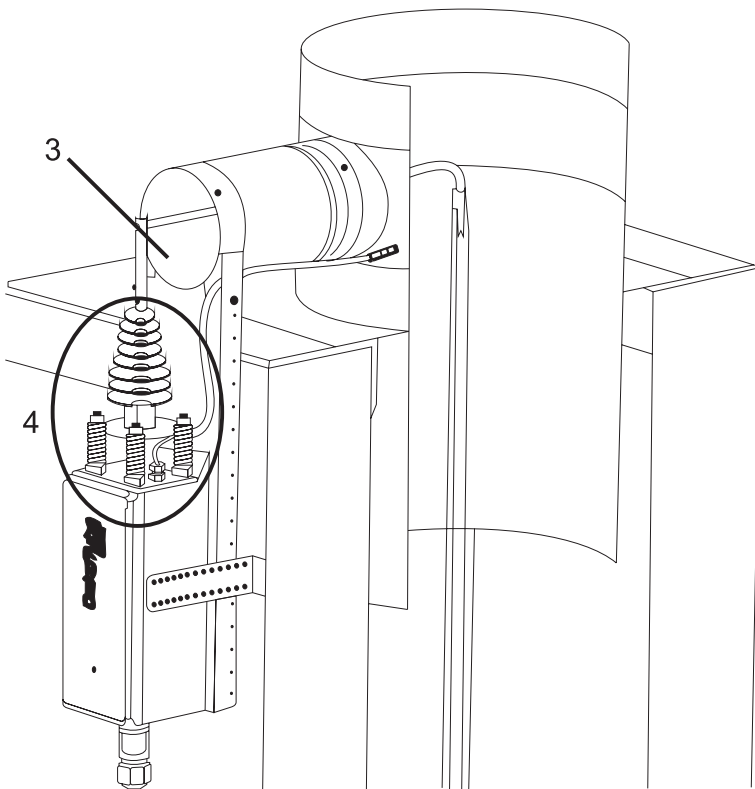

Fault Indication / Fault Reason

List of cause of error

Symptom	Fault	Action (disconnect always the electricity supply)
Standby despite temperature rising into the exhaust duct	Temperature sensor is not inserted into the exhaust duct	Fix the temperature sensor
Slow or never in operating state after the firing of the fire	The high voltage is not switched on	Open cover of the control box, choose the operating temperature
	Appliance: the exhaust temperature is rising too slowly	Regulate the starting temperature through Dipswitch on 35°C (look on the label on the inner side of the control boxcover)
Damaged cable of temperature sensor	Sight check / check temperature sensor - cable	Replace temperature sensor, replace the control box
Short / LED permanent on red	Electrode not (anymore) centered	Center the electrode using the 4 nuts
	Hexagonal bar not cut down to size	Cut the hexagonal bar to the appropriate length
	Dirty extension pipe (130 mm entry)	Clean
	Dirty exhaust canal	Clean
	High voltage cable damaged below the insulator (sight control)	Replace the electronic box
	High voltage cable inside the electronic box damaged (beat inside of the box hearable)	Replace the electronic box
	Dirty insulator	Clean the insulator
LED permanent on red after cleaning	Problem with the temperature sensor: damaged cable	Replace the cable
	Misaligned electrode	Center the electrode and fit the nuts
	Ash accumulation in the 130 mm opening	Clean
LED on red blinking	Temperature sensor is not connected	Control the connection of the temperature sensor / damaged cable (replace)
	Cover is not fixed right	Fix it the right way
	Missing magnet	Replace magnet
LED no color	Bent cover	Straighten the cover to reduce the distance to the control box (contact inside the box)
	Plug is not connected	Connect the plug
	No power on the plug	Check the electrical connection
	Wire inside the control box is not connected correctly	Connect the wire right
	No power on the ACDC / ACDC defect	Replace the control box

Hexagonal bar is not trimmed to length



Wrong



Right

Missing magnet, or it is too far away from the contact

On the inside of the cover there is fixed a magnet. If the cover is not fixed right or the magnet is missing, the ePURO filter cannot switch-on (LED note: red blinking).

Soot build up in the extension tube and / or the insulator

If the insulator is overused, it will become conductive. The system refuses to function (LED note: permanent red).
If there is ash in the extension pipe, it leads to shorts with the hexagon (LED note: permanent red).

The electrode is not centered

If the nuts are not tightened enough, the electrode can adjust itself during the first cleaning. That leads to a short between the electrode and the chimney. The system refuses to function (LED note: permanent red).

The electrode is too long

If the last vertical space of the exhaust canal is under 1.6 m, it leads to a short between the electrode and the chimney. The system refuses to function (LED note: permanent red).

Dip-Switches Setting

The following parameters can be adjusted by setting the dip switches:

- Activation of display or ModBus address
- Maximum voltage level
- Switch-on behaviour or switch-on temperature

Setting Dip-Switches

The ePURO filter is delivered with factory settings. No changes to the dip switches are necessary. Settings are to be made exclusively after consultation with the manufacturer or supplier.

The information printed on the sticker on the inside of the cover of the control electronics applies.

Factory setting

The factory settings are as follows:

- no display is connected,
- the high voltage is set to 22 kV,
- the separator switches on when the temperature difference between the flue gas temperature sensor and the temperature sensor in the control unit is more than 20°C.
- the temperature sensor is activated.

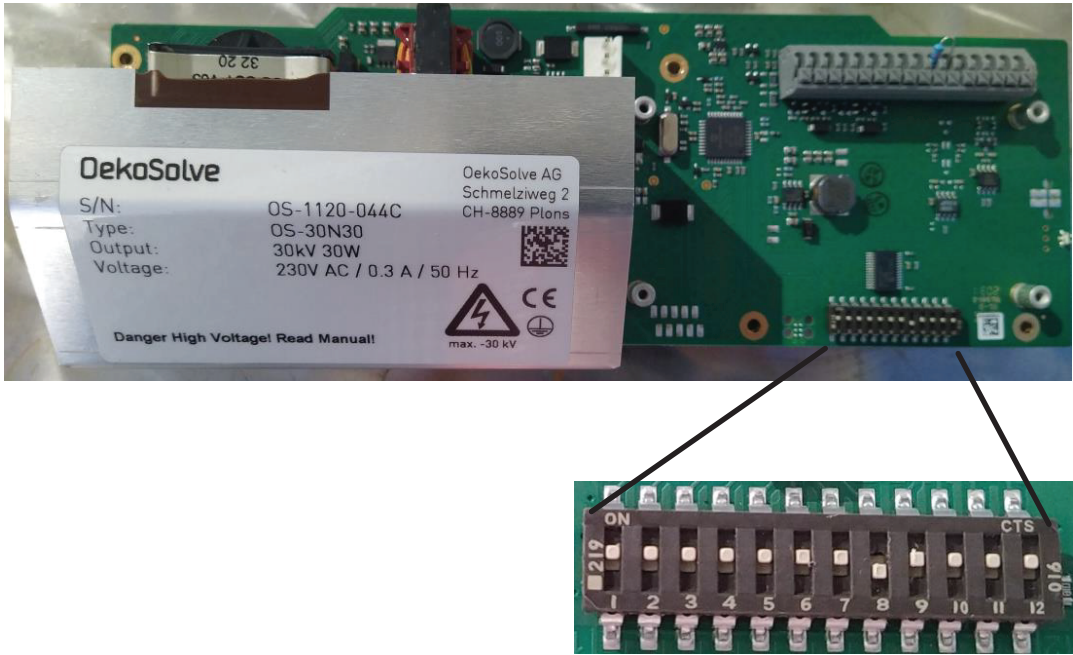

DipSwitch

The settings for the voltage level can be adjusted if necessary to increase the separator efficiency and operational safety. The following recommendations apply depending on the diameter of the separator or the flue gas pipe:

ePURO filter Settings

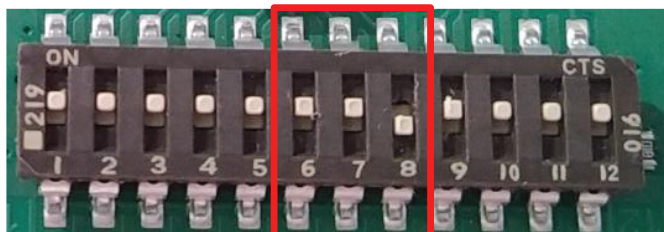

1	2	3	4	5	6	7	8	9	10	11	12
Address					U.limit [kV]			Temp. [°C]			
<<111 = 31"					111 = 30			111 = +Δ20			
011 = 6					011 = 28			011 = +Δ13			
101 = 5					101 = 26			101 = +Δ5			
001 = 4					001 = 24			001 = +Δ0			
110 = 3					110 = 22			110 = 65			
010 = 2					010 = 20			101 = 45			
100 = 1					100 = 18			100 = 35			
000					000 = Soft			000 = (ON)			
					not used						
											1 = enable 0 = disable
											Temp. sensor

Recommendation according to the cross-section of the flue pipe

130 mm	22 kV (factory setting)
150 mm	24 kV
180 mm and more	30 kV

Switch-on behaviour

The system switches on when the temperature difference between the exhaust gas temperature sensor and the temperature sensor in the control unit is more than 20 °C (factory setting).

To change the switch-on behavior, dip switches 9, 10 + 11 must be adjusted accordingly

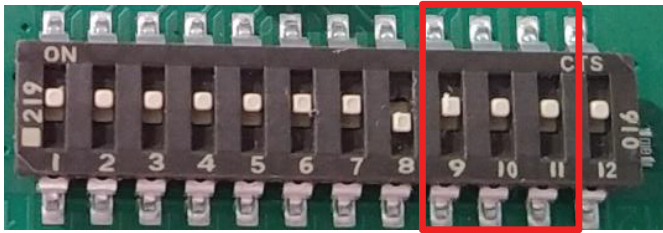

Recommendation according to installation location

Separator in the boiler room	+Δ 20°C (Factory setting)
Separator in the chimney	+Δ 13°C
Separator on the chimney mouth	+Δ 5°C

ePURO filter Settings

1	2	3	4	5	6	7	8	9	10	11	12
Address			1 = Slave (read only) 0 = Master (write)	not used	U.limit [kV]			Temp. [°C]			1 = enable 0 = disable Temp. sensor
«111 = 31"					111 = 30	111 = +Δ20					
011 = 6					011 = 28	011 = +Δ13					
101 = 5					101 = 26	101 = +Δ5					
001 = 4					001 = 24	001 = +Δ0					
110 = 3					110 = 22	110 = 65					
010 = 2					010 = 20	101 = 45					
100 = 1			100 = 18	100 = 35							
000			000 = Soft	000 = (ON)							

Explanation of switch-on behaviour

Explanation of switch-on behaviour
°C

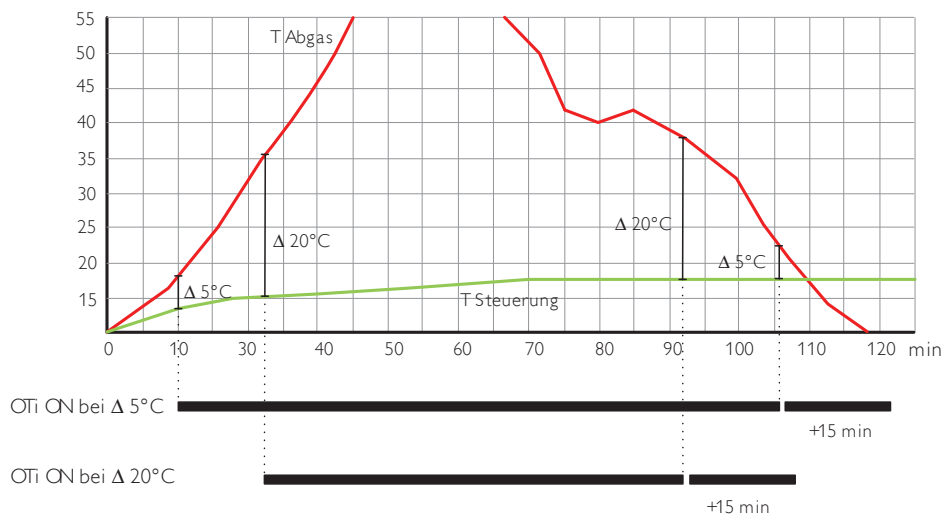

Addressing the HV modules

Dipswitches 1-3 are reserved for addressing the digital interface. These are not relevant for the use of the ePURO filter and should be left at the factory settings.

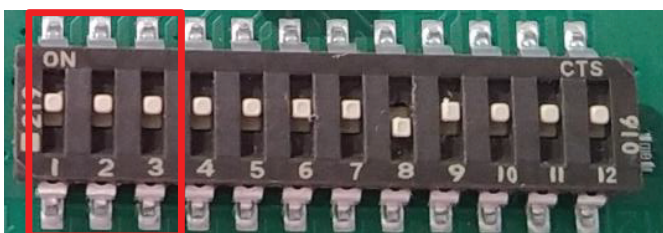

ePURO filter Settings

1	2	3	4	5	6	7	8	9	10	11	12
Address			1 = Slave (read only) 0 = Master (write)	not used	U.limit [kV]			Temp. [°C]			1 = enable 0 = disable Temp. sensor
«111 = 31"					111 = 30	111 = +Δ20					
011 = 6					011 = 28	011 = +Δ13					
101 = 5					101 = 26	101 = +Δ5					
001 = 4					001 = 24	001 = +Δ0					
110 = 3					110 = 22	110 = 65					
010 = 2					010 = 20	101 = 45					
100 = 1			100 = 18	100 = 35							
000			000 = Soft	000 = (ON)							

Display as Master

If a display is connected, then dip switch 4 must be set to OFF. The ePURO filter thus takes over the settings made on the display.

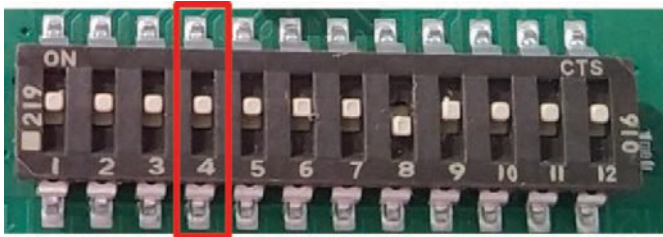





ePURO filter Settings

1	2	3	4	5	6	7	8	9	10	11	12
Address					U.limit [kV]			Temp. [°C]			
<111 = 31"					111 = 30			111 = +Δ20			
011 = 6					011 = 28			011 = +Δ13			
101 = 5					101 = 26			101 = +Δ5			
001 = 4					001 = 24			001 = +Δ0			
110 = 3					110 = 22			110 = 65			
010 = 2					010 = 20			101 = 45			
100 = 1					100 = 18			100 = 35			
000					000 = Soft			000 = (ON)			
				1 = Slave (read only) Display	not used						
				0 = Master (write)				1 = enable 0 = disable			
								Temp. sensor			

Type Plate

S/N: OTi-0422-238
 Type: OTi-1
 Voltage: 230 V AC / 0,2 A / 50 Hz
 Rated Power: 60 W
 Protection Cat: 1

Danger High Voltage! Read Manual!

The following information is available on the type plate:

- S/N: Serial number
- Type: Technical design of the separator
- Voltage: Electrical supply voltage
- Rated Power: Electrical power consumption
- Protection Cat.: Electrical protection class

EC Declaration of Conformity

The manufacturer: OekoSolve AG

Schmelziweg 2

CH-8889 Plons-Mels SG

Tel. +41 (0)81 511 63 00

info@oekosolve.ch

www.oekosolve.ch

hereby declares that the following product:

Product designation: ePURO filter, Fine dust separator for wood firing systems

Type designation: OT-1 (D130 up to D300)

complies with all provisions of the Low Voltage Directive (2014/35/EU) and the Directive 2014/30/EU on electromagnetic compatibility.

The following harmonised standards were applied

EN 61000-6-1: 2019	Electromagnetic compatibility (EMC) - Part 6-1: Generic standards - Immunity standard for residential, commercial and light-industrial environments
EN 61000-6-2: 2019	Electromagnetic compatibility (EMC) - Part 6-2: Generic standards - Immunity for industrial environments
EN 61000-6-3: 2007	Electromagnetic compatibility (EMC) - Part 6-3: Generic standards - Emission standard for residential, commercial and light-industrial environments
EN 61000-6-4: 2019	Electromagnetic compatibility (EMC) - Part 6-4: Generic standards - Emission standard for industrial environments
EN 60335-1:2020	Household and similar electrical appliances - Safety - Part 1: General requirements

Documentation officer: Beat Müller, Tel. +41 (0)81 511 63 00

Plons, in february 2021



Beat Müller, Managing Director

Fact Sheet ePURO filter

Technical data						
kW installed boiler output, kW	50 kW					
Separation effect, %	85-95% Reduction of the number of particles 50-90% Reduction of the total particle mass					
Max. Exhaust gas temperature, °C	250°C					
Space requirement						
Installation	On the top of the chimney					
Weight						
Weight (without control and without insulation), kg	ca. 8 kg					
Chimney connection						
Wall thickness, m	1 mm					
T-piece diameter, m	130	150	180	200	250	300
Pressure loss, Pa	0					
Electrical connection						
Power connection	230 AC / max. 13 A					
Max. Power consumption, W	30					
High voltage						
Max. Voltage electrode, V	30'000					
General information						
Sound pressure level, dB (A)	0					
Material	Stainless steel 1.4404 (V4A)					
Max. Ambient temperature, °C	40					



Schiedel Isokern

Unit 8/9 Block A, Holton Road,
Holton Health Industrial Est., Poole
BH16 6LG
T +44 1202 861650

sales.uk@schiedel.com
www.schiedel.com/uk

Follow us on Social Media @SchiedelUK



A **stañdard**
INDUSTRIES COMPANY